

CLIP FOR VERTICAL FINISHING

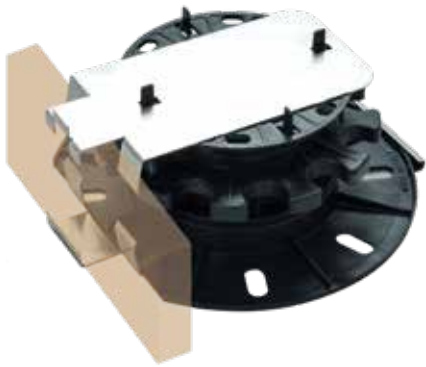

INDEX

1. Code Registry
2. Use
3. Technical Specification

1. CODE REGISTRY

Code	Description	Dimension (mm)	Weight	Pkg. / Pallet
TER09-1146/C	Base clip for vertical finishing - 10 mm	-	- kg/pcs	80 pcs. / - pcs.
TER09-1146/E	Head clip for vertical finishing - 10 mm	-	- kg/pcs	80 pcs. / - pcs.
TER09-1146/D	Base clip for vertical finishing - 20 mm	-	- kg/pcs	80 pcs. / - pcs.
TER09-1146/F	Head clip for vertical finishing - 20 mm	-	- kg/pcs	80 pcs. / - pcs.

MATERIAL Made of stainless steel.

TER09-1146/C

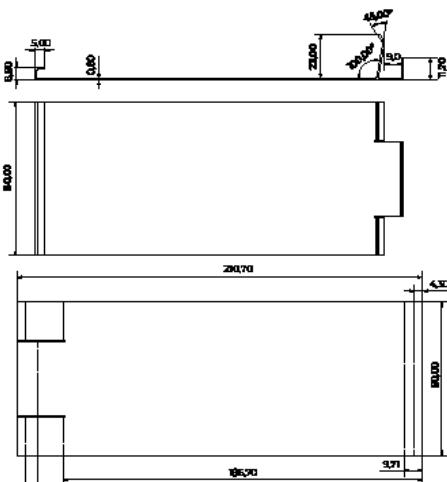

TER09-1146/E

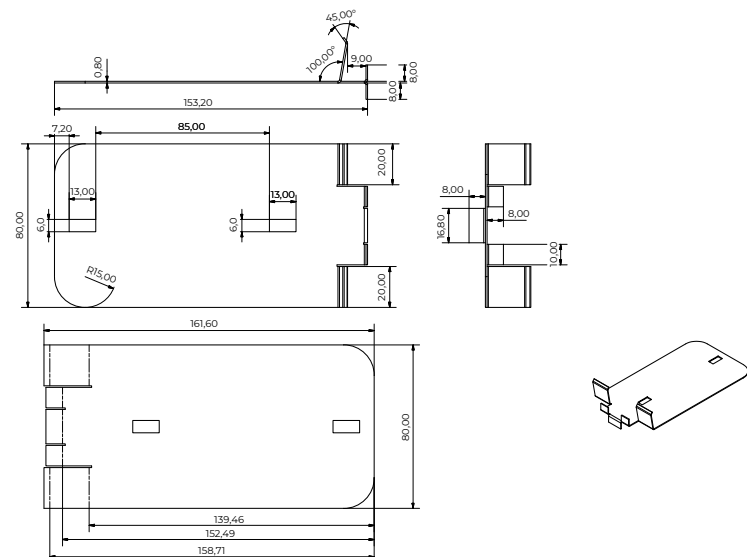

CLIP FOR VERTICAL FINISHING

TER09-1146/D

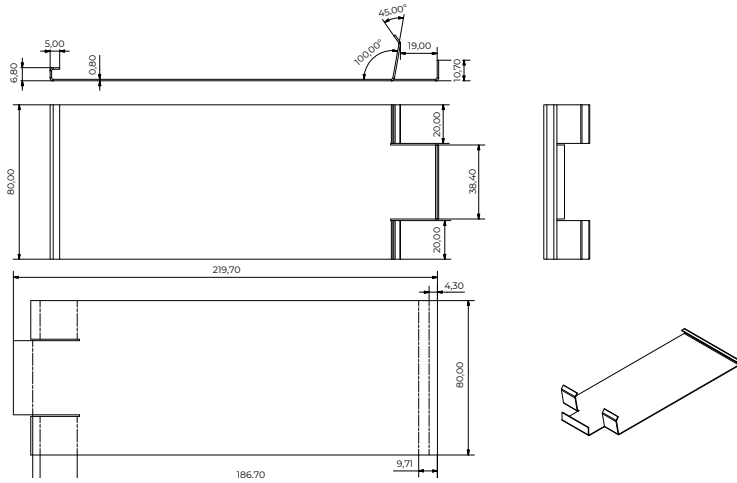

TER09-1146/F

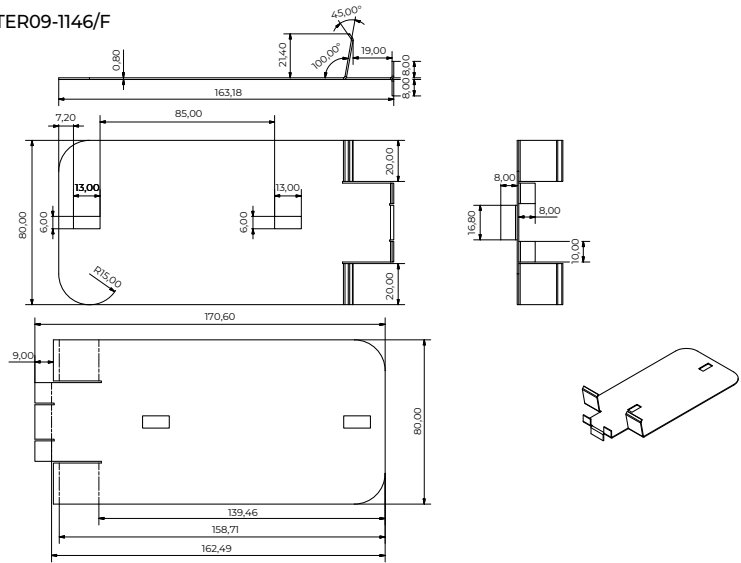

2. USE

Used for laying of perimeter tiles with Dakota raised floor supports.

3. TECHNICAL SPECIFICATION

Specification	Description	Unity	Price
Dak.O.TER09.1146/A	Supply and installation of universal clip for the perimeter laying of tiles for floating floors. The clip avoids the contact between the tiles and the wall, thanks to its special shape that absorbs all possible movements and dilatations. Specifically designed for application with all Dakota floating supports: Arkimede, Arkimede Nano and 3d-Scopic. Made of stainless steel. Used for laying of perimeter tiles with Dakota raised floor supports.	pcs	-