

# POLYETHYLENE BOX FOR METERS

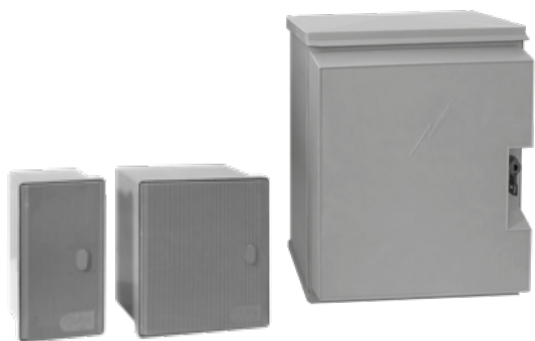

## INDEX

1. Code Registry
2. Description
3. Use
4. Complementary elements
5. Technical specification

## 1. CODE REGISTRY

Codice	Descrizione	Misure (mm)	Peso	Pkg. / Pallet
TER31-7096	Box for Meters 1 P	232 x 420 x 210	3,000 kg/pc.	1 pc. / 30 pcs.
TER31-7097	Box for Meters 2 P	390 x 420 x 230	5,000 kg/pc.	1 pc. / 14 pcs.
TER31-7095	Box for Meters 4 P	685 x 640 x 235	5,000 kg/pc.	1 pc. / 8 pcs.
TER31-7098	Support pole	1,420 x ø 120	2,500 kg/pc.	1 pc. / - pcs.
TER31-7099	Pole bracket	170 x 260 x 17	1,000 kg/pc.	1 pc. / - pcs.

### MATERIAL

Box made of ABS, particularly resistant to ageing due to exposure to atmospheric agents. Bracket made of steel, pole in fiberglass.

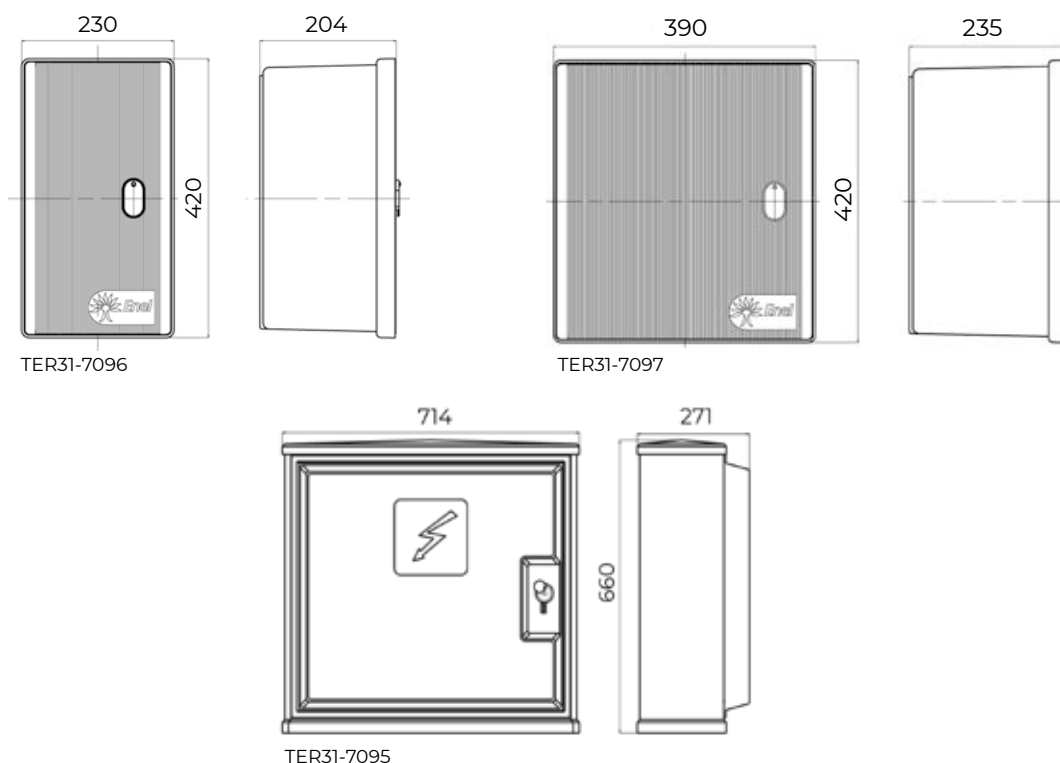

# POLYETHYLENE BOX FOR METERS

## 2. DESCRIPTION

The Polyethylene box is designed to fit electricity meters, equipped with anti-condensation protection IP, double bit lock and supplied with a key internal set up for connection of the meters, according to energy norms. The support pole is made of fiberglass and is designed to house the polyethylene box, while the bracket is made of Fe 360 B steel.

## 3. USE

To cover and protect meters embedded in the wall, allowing periodic reading.

## 4. COMPLEMENTARY ELEMENTS

The support post and bracket are the necessary elements to complete the installation of the polyester box.



### Technical features galvanized bracket

- Steel Fe 360 B according to UNI EN 10025 of 1990
- Hot dip galvanization according to CEI 7-6 standard

### Features of the artefact

- Suitable for mounting on containers for GMI-Y and GTI-Y type measuring groups for pole fixing
- Reference to Technical Specification ENEL DS 4557 National
- The bracket is fixed to the enclosure with three M8 stainless steel hexagon socket screws and, in turn, fixed to the pole by means of a special steel tape.

# POLYETHYLENE BOX FOR METERS

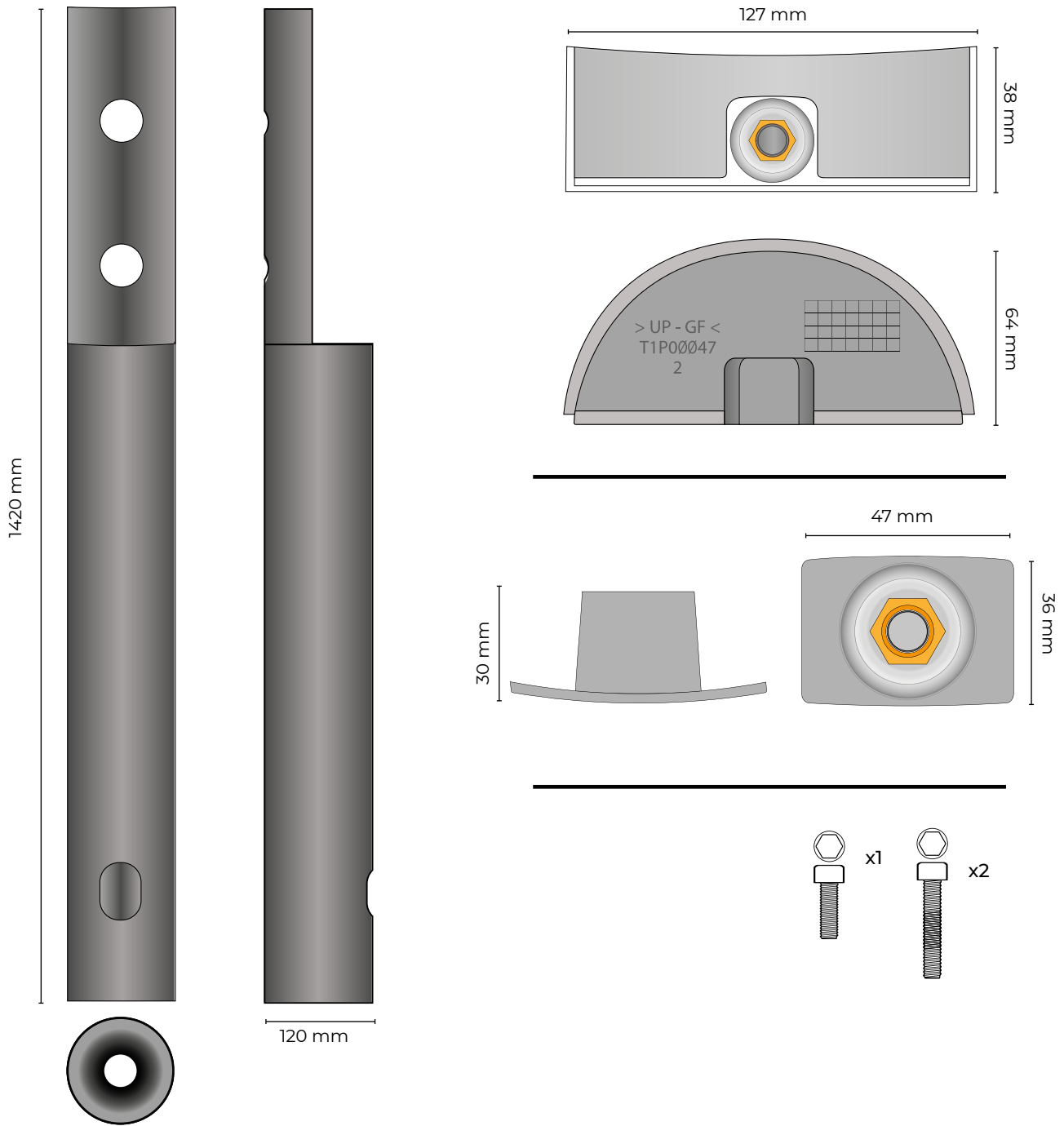

## 5. VOCI DI CAPITOLATO

Item	Description	Unit	Price
<b>Dak.O.TER31.709x</b>	Supply and installation of box designed to house electricity meters, equipped with IP anti-condensation protection, double map lock and key supplied with internal preparation for the connection of the meters and approved according to the regulations energy manager. Packed in box. Made of polyester resin, is particularly resistant to impact and aging by exposure to weathering. To accommodate single or double electricity meters, protect them from tampering and / or vandalism and allow the periodic reading or maintenance.		
<b>Dak.O.TER31.7096</b>	Dimensions 232 x 420 x 210 mm.....	pc.	-
<b>Dak.O.TER31.7097</b>	Dimensions 390 x 420 x 230 mm.....	pc.	-
<b>Dak.O.TER31.7095</b>	Dimensions 685 x 640 x 235 mm.....	pc.	-
<b>Dak.O.TER31.7098</b>	Dimensions 1.420 x ø 120 mm.....	pc.	-
<b>Dak.O.TER31.7099</b>	Dimensions 170 x 260 x 17.....	pc.	-