

# CAST IRON ANTI-HEEL GRATING 130



## INDEX

1. Code Registry
2. Description
3. Use
4. Technical Specification

## 1. CODE REGISTRY

Code	Description	Dimension (mm)	Weight	Colour	Pkg. / Pallet
POZ90-135IHB	B125 Cast Iron Anti-heel Grating	130 x 500 x 20	2,80 kg/pc.	Black	1 pc. / 260 pcs
POZ90-135IHC	C250 Cast Iron Anti-heel Grating	130 x 500 x 20	3,45 kg/pc.	Black	1 pc. / 260 pcs

**MATERIAL** Made of spheroidal cast iron.

**CERTIFICATION** The item is engraved in accordance to EU regulation UNI 1433.

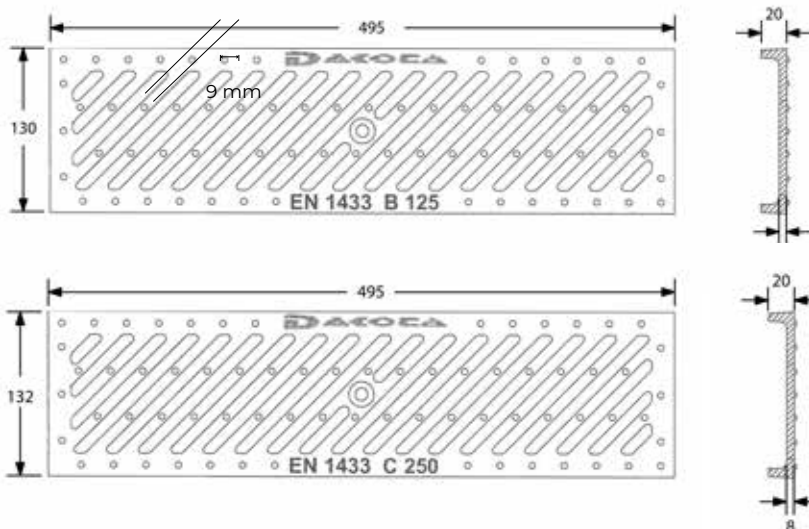

## 2. DESCRIPTION

Grating for Dakota Channels with heel proof mesh design. Available load class: B125

## 3. USE

It can be used in areas that need high load capacity (heavy traffic and/or heavy vehicles passage, respecting the corresponding loading class).

## 4. TECHNICAL SPECIFICATION

Specification	Description	Unity	Price
<b>Dak.D.POZ90.135IHx</b>	Supply and installation to Made with Anti-heel squared mesh design. Available loading classes: B125 - C250. Made of spheroidal cast iron. It can be used in areas that need high load capacity (heavy traffic and/or heavy vehicles passage, respecting the corresponding loading class).		
<b>Dak.D.POZ90.135IHB</b>	Class B125.....	pc.	-
<b>Dak.D.POZ90.135IHC</b>	Class C250.....	pc.	-