

# DRAINING WATER OUTLET WITH PERFORATED FLANGE



## INDEX

1. Code Registry
2. Use
3. Technical Specification

## 1. CODE REGISTRY

Code	Description	Dimension (mm)	Weight	Pkg. / Pallet
BOC01-1109F	Draining water outlet with perforate flange	ø 63	0,198 kg/pcs.	25 pcs. / 150 pcs.
BOC01-1109SF	Draining water outlet with perforate flange	ø 75	0,190 kg/pcs.	25 pcs. / 150 pcs.
BOC01-1110F	Draining water outlet with perforate flange	ø 80	0,192 kg/pcs.	25 pcs. / 150 pcs.
BOC01-1110SF	Draining water outlet with perforate flange	ø 90	0,193 kg/pcs.	25 pcs. / 150 pcs.
BOC01-1111F	Draining water outlet with perforate flange	ø 100	0,195 kg/pcs.	20 pcs. / 120 pcs.
BOC01-1111SF	Draining water outlet with perforate flange	ø 110	0,362 kg/pcs.	20 pcs. / 120 pcs.
BOC01-1112F	Draining water outlet with perforate flange	ø 125	0,215 kg/pcs.	20 pcs. / 120 pcs.

**MATERIAL** Made of TPE (thermoplastic elastomer).

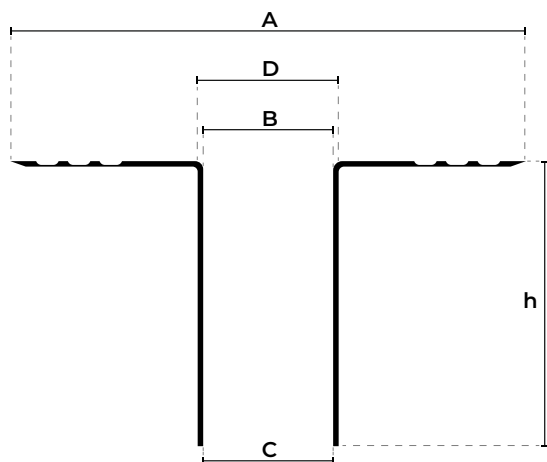

measurements in mm

CODE	A	B	C	D*	h
BOC01-1109F	300	50	50	54	235
BOC01-1109SF	300	65	65	64	235
BOC01-1110F	300	70	70	76	240
BOC01-1110SF	300	80	80	86	235
BOC01-1111F	300	90	90	93	235
BOC01-1111SF	300	100	100	106	235
BOC01-1112F	300	107	105	109	235

# DRAINING WATER OUTLET WITH PERFORATED FLANGE

## 2. USE

Used for vertical evacuation of rainwater in flat roofs.

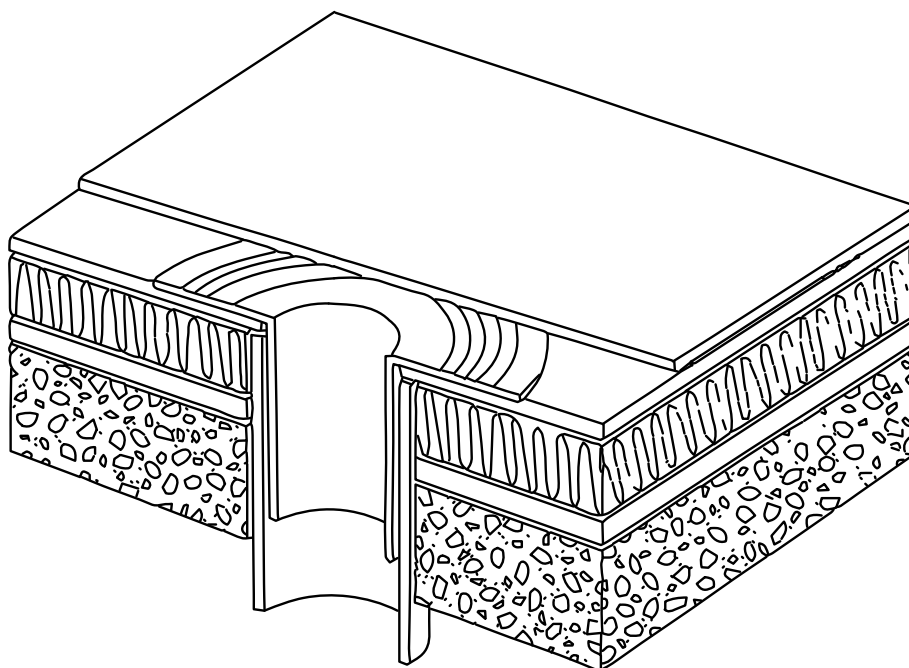

## 3. TECHNICAL SPECIFICATION

Specification	Description	Unity	Price
<b>Dak.O.BOC01.110xF</b>	Supply and installation of draining water outlet consists in a perforated flange to improve the connection to the waterproofing membrane. Tube has a length of 240 mm and diameters from 63 to 125 mm. Made of TPE (thermoplastic elastomer). Used for vertical evacuation of rainwater in flat roofs.		
<b>Dak.O.BOC01.1109F</b>	Dimension $\varnothing$ 63 mm.....	pc.	-
<b>Dak.O.BOC01.1109SF</b>	Dimension $\varnothing$ 75 mm.....	pc.	-
<b>Dak.O.BOC01.1110F</b>	Dimension $\varnothing$ 80 mm.....	pc.	-
<b>Dak.O.BOC01.1110SF</b>	Dimension $\varnothing$ 90 mm.....	pc.	-
<b>Dak.O.BOC01.1111F</b>	Dimension $\varnothing$ 100 mm.....	pc.	-
<b>Dak.O.BOC01.1111SF</b>	Dimension $\varnothing$ 110 mm.....	pc.	-
<b>Dak.O.BOC01.1112F</b>	Dimension $\varnothing$ 125 mm.....	pc.	-