

# RUSH LEVEL



## INDEX

1. Code Registry
2. Description
3. Use
4. Synoptic consumption per square meter
5. Technical Specification

## 1. CODE REGISTRY

| Code         | Description          | Colour | (mm) | Weight      | Bag / Pkg. / Pallet         |
|--------------|----------------------|--------|------|-------------|-----------------------------|
| TER04-4470DK | Rush Level™ Cylinder | Blue   | -    | 0,93 kg/bag | 50 pcs. / 8 bags / 120 bags |

**MATERIAL** Made of PP (polypropylene).

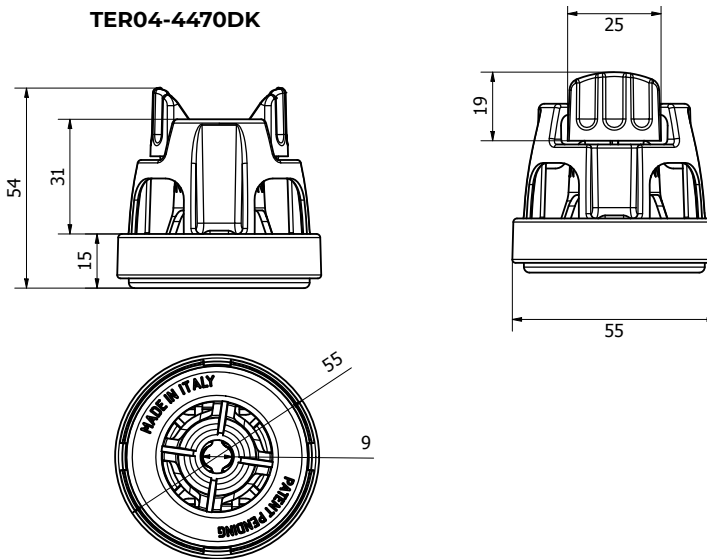

## 2. DESCRIPTION

Rush Level™ System is a new generation of cylinder leveling system.

Main features are:

- It works with all spacer clips of any shape: linear, T and X shape.
- Very easy and fast to use: soft squeeze and push for initial set and squeeze again for quick release of the broken screws once used.
- Anti-scratch rubber pad integrated to prevent any marking.
- Wide working range for tiles from 3 to 22 mm and from 20 to 30 with linear screw TER04-4443DK (only for 3 mm thickness).
- Joint lines available: Linear 1, 1.5, 2, 2.5, 3 and 4 mm (3/64, 1/16, 5/64, 7/64, 1/8 and 5/32inch), Cross an T-shape 1, 2, 3 mm (3/64, 5/64 and 1/8inch) only.

Rush Level™ is available in two different packagings:

- Single bags composed of 100 disposable screws or 50 cylinders,
- Plastic box composed of 100 disposable linear screws and 50 leveling cylinders;

# RUSH LEVEL

## 3. USE

Leveling system and spacer for floor and wall tiles of various sizes and thicknesses.

## 4. SYNOPTIC CONSUMPTION PER SQUARE METER

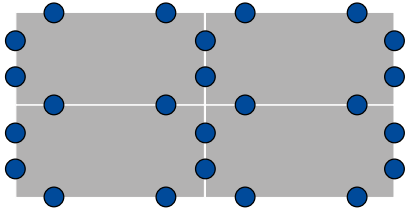

| A   | 10  | 15 | 20 | 25 | 30 | 40 | 45 | 50 | 60 | 80 | 90 | 100 | 120 | B |
|-----|-----|----|----|----|----|----|----|----|----|----|----|-----|-----|---|
| 10  | 200 |    |    |    |    |    |    |    |    |    |    |     |     |   |
| 15  | 133 | 89 |    |    |    |    |    |    |    |    |    |     |     |   |
| 20  | 100 | 67 | 50 |    |    |    |    |    |    |    |    |     |     |   |
| 25  | 80  | 53 | 40 | 32 |    |    |    |    |    |    |    |     |     |   |
| 30  | 100 | 67 | 50 | 40 | 44 |    |    |    |    |    |    |     |     |   |
| 40  | 75  | 50 | 37 | 30 | 33 | 25 |    |    |    |    |    |     |     |   |
| 45  | 67  | 44 | 33 | 27 | 30 | 22 | 20 |    |    |    |    |     |     |   |
| 50  | 60  | 45 | 30 | 24 | 27 | 20 | 13 | 16 |    |    |    |     |     |   |
| 60  | 50  | 33 | 25 | 20 | 22 | 17 | 15 | 10 | 11 |    |    |     |     |   |
| 80  | 50  | 33 | 25 | 20 | 21 | 16 | 14 | 15 | 10 | 9  |    |     |     |   |
| 90  | 44  | 30 | 22 | 18 | 19 | 14 | 12 | 15 | 9  | 8  | 7  |     |     |   |
| 100 | 50  | 33 | 25 | 20 | 20 | 15 | 13 | 15 | 10 | 9  | 8  | 8   |     |   |
| 120 | 42  | 28 | 21 | 17 | 17 | 13 | 11 | 15 | 8  | 7  | 6  | 7   | 6   |   |
| cm  | 10  | 15 | 20 | 25 | 30 | 40 | 45 | 50 | 60 | 80 | 90 | 100 | 120 | B |

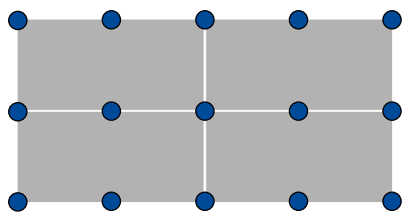
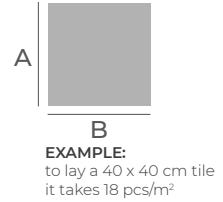

| A   | 10 | 15 | 20 | 25 | 30 | 40 | 45 | 50 | 60 | 80 | 90 | 100 | 120 | B |
|-----|----|----|----|----|----|----|----|----|----|----|----|-----|-----|---|
| 10  | 98 |    |    |    |    |    |    |    |    |    |    |     |     |   |
| 15  | 65 | 43 |    |    |    |    |    |    |    |    |    |     |     |   |
| 20  | 49 | 32 | 24 |    |    |    |    |    |    |    |    |     |     |   |
| 25  | 39 | 26 | 19 | 15 |    |    |    |    |    |    |    |     |     |   |
| 30  | 32 | 21 | 16 | 13 | 11 |    |    |    |    |    |    |     |     |   |
| 40  | 49 | 32 | 24 | 19 | 16 | 18 |    |    |    |    |    |     |     |   |
| 45  | 43 | 29 | 21 | 17 | 14 | 16 | 14 |    |    |    |    |     |     |   |
| 50  | 39 | 26 | 19 | 15 | 13 | 14 | 13 | 11 |    |    |    |     |     |   |
| 60  | 32 | 21 | 16 | 13 | 11 | 12 | 10 | 9  | 8  |    |    |     |     |   |
| 80  | 36 | 24 | 18 | 14 | 12 | 12 | 10 | 9  | 8  | 7  |    |     |     |   |
| 90  | 32 | 21 | 16 | 13 | 11 | 10 | 9  | 8  | 7  | 6  | 6  |     |     |   |
| 100 | 29 | 19 | 14 | 11 | 9  | 9  | 8  | 7  | 6  | 6  | 5  | 4   |     |   |
| 120 | 32 | 21 | 16 | 13 | 11 | 10 | 9  | 8  | 6  | 6  | 5  | 4   | 4   |   |
| cm  | 10 | 15 | 20 | 25 | 30 | 40 | 45 | 50 | 60 | 80 | 90 | 100 | 120 | B |

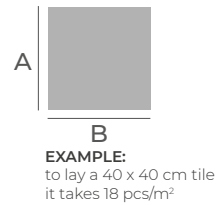

## 5. TECHNICAL SPECIFICATION

| Specification      | Description   | Unity | Price |
|--------------------|---|-------|-------|
| Dak.I.TER04.44xxDx | Supply and installation of Rush Level™: a new generation of cylinder leveling system.<br>A system to remove any difference between tile and tile during the laying, obtaining a coplanar and equidistant result without any lippage.<br>works with all spacer clips of any shape: linear, T and X shape.<br>Anti-scratch rubber pad integrated to prevent any marking<br>Made of PP (polypropylene).<br>available in two different packagings:<br><ul style="list-style-type: none"> <li>Single bags composed of 100 disposable screws or 50 cylinders,</li> <li>Plastic box composed of 100 disposable linear screws and 50 leveling cylinder</li> </ul> | bags  | -     |
| Dak.I.TER04.4470DK | Cylinder - Blue.....  | bags. | -     |