

WINDOWPROOF KIT FOR ARKIMEDE™



INDEX

1. Registry code
2. Description
3. Use
4. Technical specification

1. REGISTRY CODE

Code	Description	Measures (mm)	Weight (kg)	Pkg. / Pallet
TER09-2299/W3L20	Windproof kit for Arkimede™ - 3 mm joint	Thickness 3 mm	0,02	50 pcs. / 7.200 pcs.
TER09-2299/W4L20	Windproof kit for Arkimede™ - 4 mm joint	Thickness 4 mm	0,02	50 pcs. / 7.200 pcs.
TER09-2299/W3H20	Windproof kit for Arkimede™ - 3 mm joint	Thickness 3 mm	0,02	50 pcs. / 7.200 pcs.
TER09-2299/W4L20	Windproof kit for Arkimede™ - 4 mm joint	Thickness 4 mm	0,02	50 pcs. / 7.200 pcs.

MATERIAL

Made of PA (Polyammide).

Version with 3 mm tabs

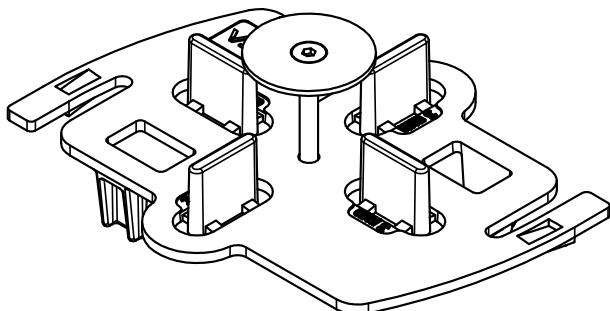

Version with 4 mm tabs

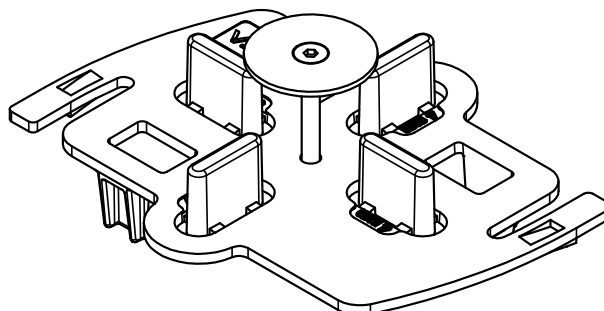

WINDOWPROOF KIT FOR ARKIMEDE™

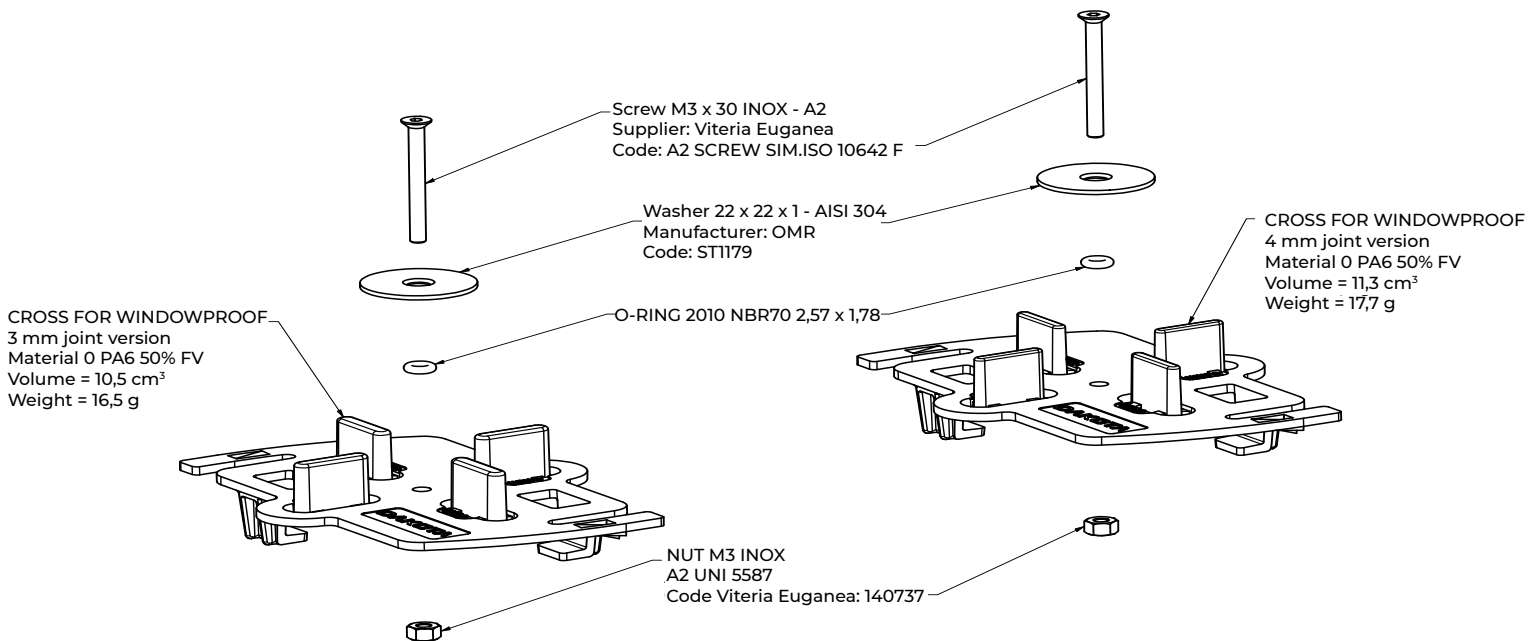

2. DESCRIPTION

Dakota's windproof kit is composed of one cross clip (joint of 3 or 4mm with breakable tabs) that fits perfectly to the Arkimede™ support, one screw (h.20 or 30mm) and one washer to block the flooring tiles.

The system is studied to connect all the tiles of the flooring in one solid surface (since they are linked to one other ones) to the Arkimede™ support.

Once all the tiles are connected together, the improved weight of the floor surface reduces the strength of wind underlying, giving an increased resistance to the whole system.

This product is available for Arkimede ® supports* only and it has to be installed uniquely with Keradeck® Aluminum joist and bajonetta adapter.

With this product external tile with thickness 20 mm only can be used and they can be fixed in 2 ways:

- Hidden fixing mode: the washer has to be placed on a hollow on the side of the tile, previously cutted. In this case has to be used the models with h.20mm screw.
- At sight fixing mode: the washer has to be placed on the top of the tiles. In this case has to be used the models with h.30mm screw.

*does not match with Arkimede 10

3. USE

Used for the perimeter finishing in the absence of a lateral wall, in the installation of raised floors with ARKIMEDE™ supports.

The adjustable clips allow the fixing of tiles of different thickness, from 8 to 38 mm, in a very easy and simple way.

Plate and Lateral Clip fit with Head for Tile (2 or 4 mm) and work with **ARKIMEDE™ 35, 41, 60 and 115 paving only.**

4. TECHNICAL SPECIFICATION

Item	Description	Unit	Price
Dak.O.TER09.2299/W3x20	Windproof kit for Arkimede™	pz.	-
Dak.O.TER09.2299/W3L20	Fuga da 3 mm		
Dak.O.TER09.2299/W4L20	Fuga da 4 mm		
Dak.O.TER09.2299/W3H20	Fuga da 3 mm		
Dak.O.TER09.2299/W4H20	Fuga da 4 mm		