

DK-MY FIX ALU SUPPORT WITH ALUMINUM PLATES



INDICE

1. Code registry
2. Description
3. Use
4. Anchor points
5. Application models
6. Resistance values
7. Installation
8. Installation tips
9. Technical specification

1. CODE REGISTRY

Code	Description	Measures (mm)	Weight (kg)	Colour	Pkg. / Pallet
ZIN35-1798/8MY	DK-MY FIX Support with aluminum plates	80 x 125 x 280	0,860	Black	12 pcs. / 288 pcs.
ZIN35-1798/10MY	DK-MY FIX Support with aluminum plates	100 x 125 x 280	0,960	Black	12 pcs. / 288 pcs.
ZIN35-1798/12MY	DK-MY FIX Support with aluminum plates	120 x 125 x 280	1,00	Black	12 pcs. / 288 pcs.
ZIN35-1798/14MY	DK-MY FIX Support with aluminum plates	140 x 125 x 280	1,05	Black	12 pcs. / 288 pcs.
ZIN35-1798/16MY	DK-MY FIX Support with aluminum plates	160 x 125 x 280	1,10	Black	12 pcs. / 288 pcs.
ZIN35-1798/18MY *	DK-MY FIX Support with aluminum plates	180 x 125 x 280	1,15	Black	12 pcs. / 288 pcs.
ZIN35-1798/20MY *	DK-MY FIX Support with aluminum plates	200 x 125 x 280	1,20	Black	12 pcs. / 288 pcs.

* to order

MATERIAL Made of polypropylene with aluminum inserts

2. DESCRIPTION

Rigid, CFC-free and rot-proof support, reinforced with two aluminum plates. Element supplied with bag containing three dowels with screws for mounting. Sizes available from 80, 100, 120, 140, 160, 180 and 200

3. USE

Support element for the external mounting of elements (such as hinges for window frames or anchorage points) ensuring the absence of thermal bridges

DK-MY FIX ALU SUPPORT WITH ALUMINUM PLATES

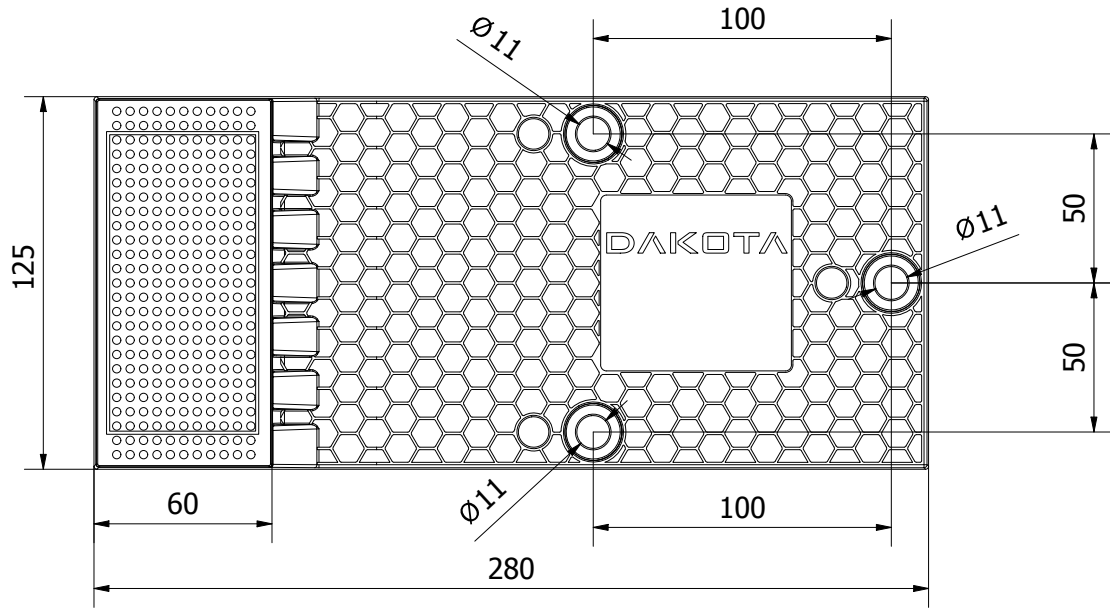

ZIN35-1798/8MY h 80 mm

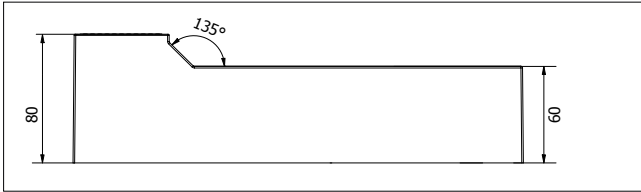

ZIN35-1798/16MY h 160 mm

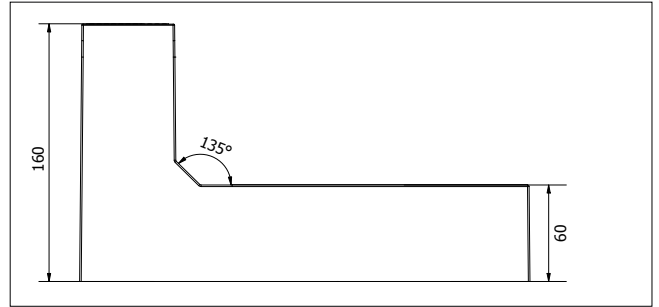

ZIN35-1798/10MY h 100 mm

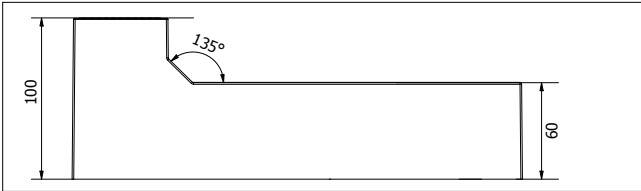

ZIN35-1798/18MY h 180 mm

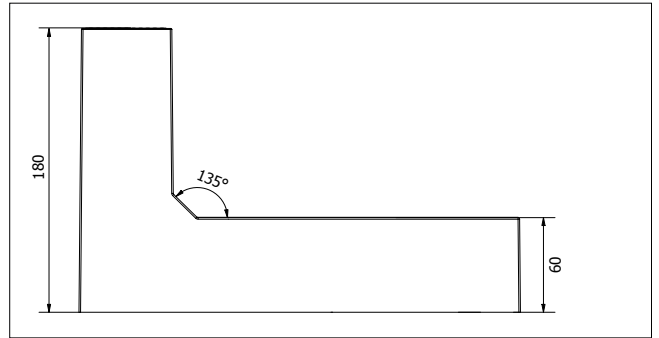

ZIN35-1798/12MY h 120 mm

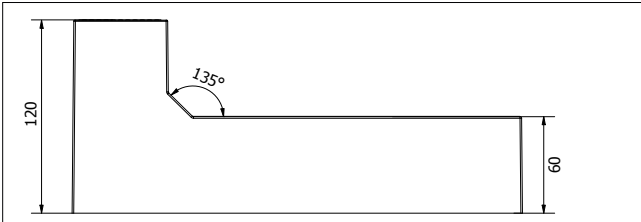

ZIN35-1798/20MY h 200 mm

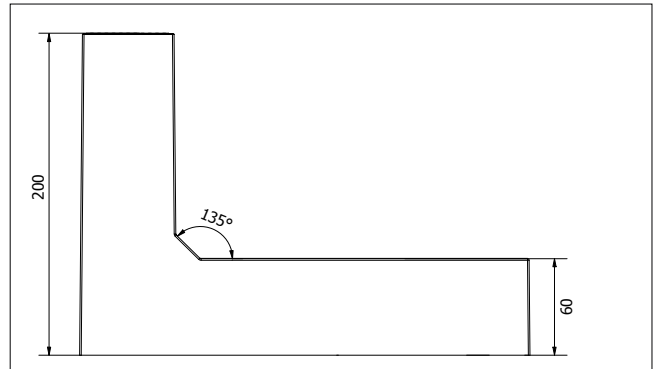

ZIN35-1798/14MY h 140 mm

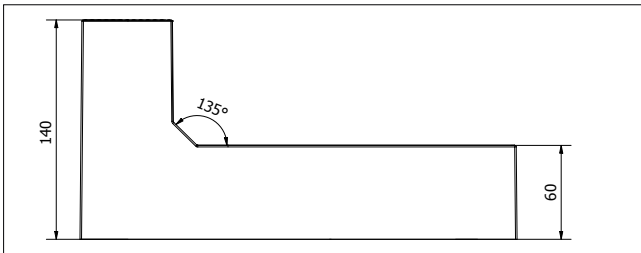

DK-MY FIX ALU SUPPORT WITH ALUMINUM PLATES

4. ANCHOR POINT

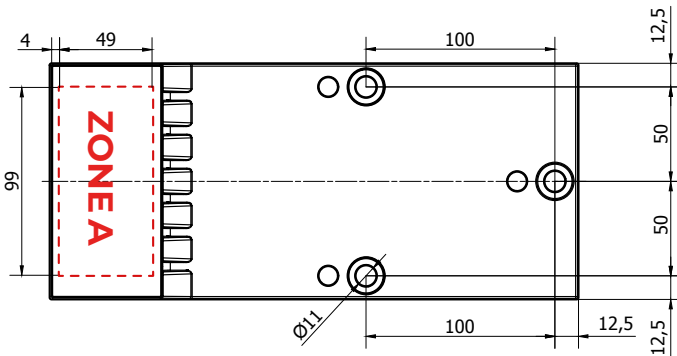
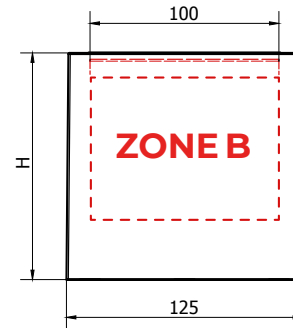
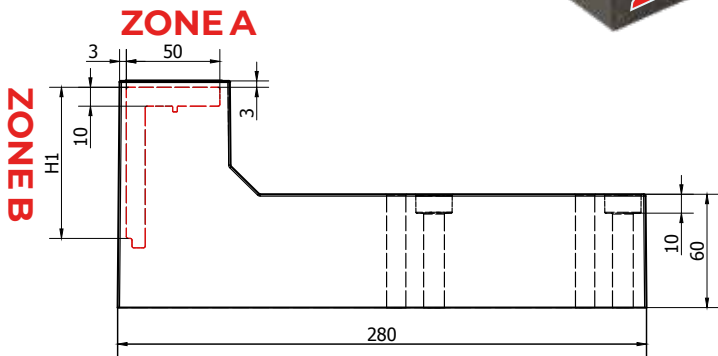

Product	TDK-MY FIX AL						
H[mm]	80	100	120	140	160	180	200
H1[mm]	60	80	80	80	80	80	80

A characteristic feature of DK-MY FIX is the presence of aluminum plates for frontal and **lateral** anchoring of support elements such as hinges for window frames, window balusters, rails for sliding shutters, parapets, and railings, allowing greater adhesion to the support for screwing elements.

This support also prevents thermal bridging during shutter installation, ensuring accurate installation.

DK-MY FIX ALU SUPPORT WITH ALUMINUM PLATES

5. APPLICATION MODELS

application of hinges for window frames

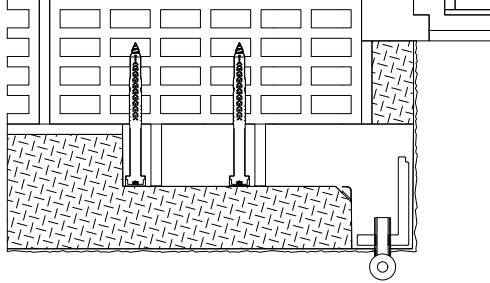

application parapets corners buildings

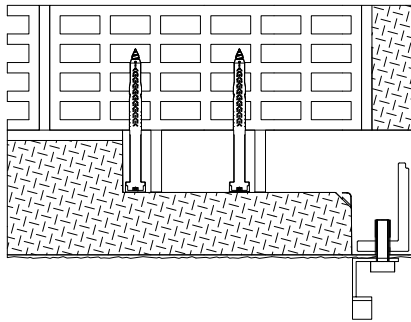

application parapets

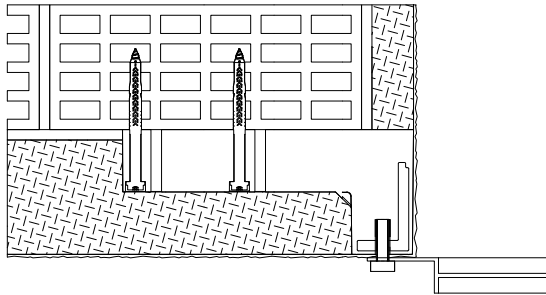

guide rail application

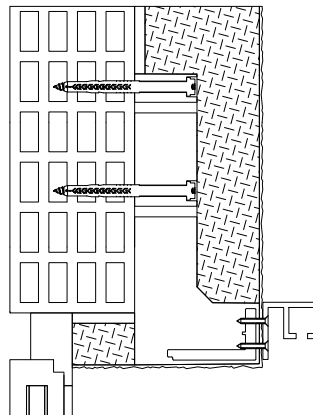

DK-MY FIX ALU SUPPORT WITH ALUMINUM PLATES

6. RESISTANCE VALUES

Characteristic breaking values

Reference system of applied forces

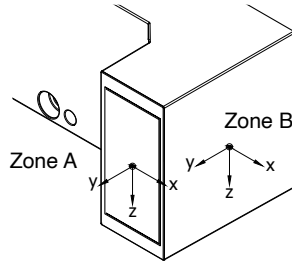

Zone A

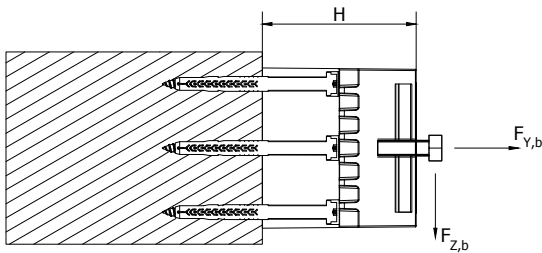

Zone B

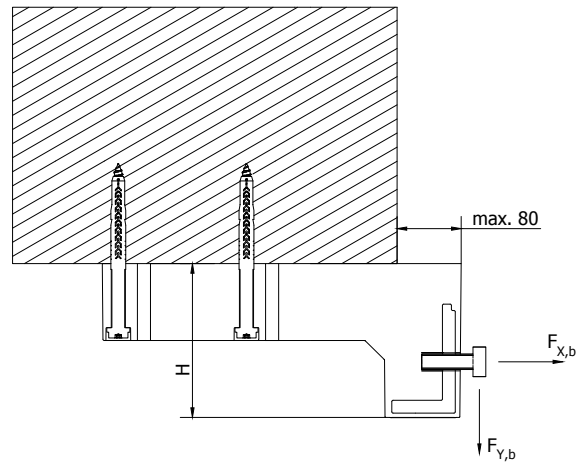
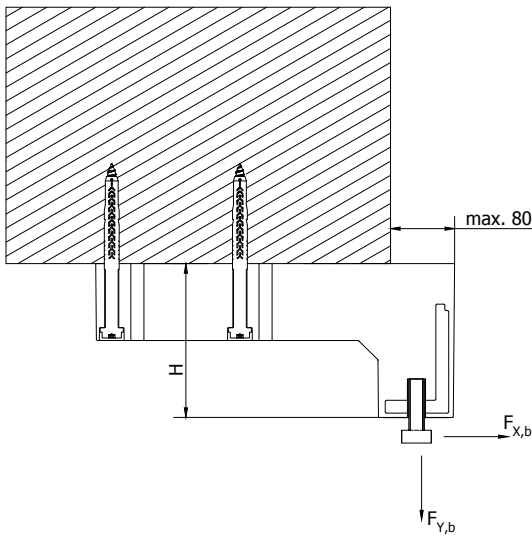
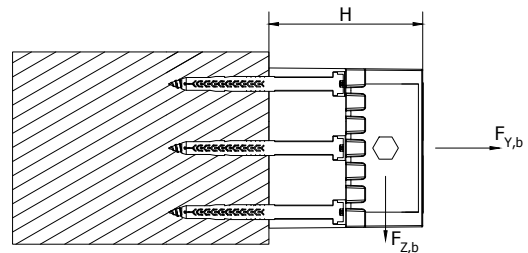

CHARACTERISTIC BREAKING VALUES [kN] - γ_m included [kN]

DK-MY FIX ALU																	
zone	unit	values							zone	unit	values						
A	H (mm)	80	100	120	140	160	180	200	B	H (mm)	80	100	120	140	160	180	200
	Fy,b,m	16,28	15,99	10,91	7,75	9,14	9,01	7,65		Fy,b,m	15,26	18,92	16,04	15,89	12,66	13,07	11,25
	Fz,b,m	7,32	7,61	7,90	8,94	7,24	8,86	8,97		Fz,b,m	6,51	6,91	6,83	7,33	5,88	7,33	7,35
	Fxb,m	5,00	5,98	5,34	5,39	4,36	4,04	4,04		Fxb,m	5,67	6,90	5,84	4,41	5,36	5,06	4,09

Meaning Designation Forces [kN]:

FX,b [kN]	Transverse force breaking load (characteristic strength)
FY,b [kN]	Lateral tensile force breaking load (characteristic strength)
FZ,b [kN]	Breaking load of axial tensile force (characteristic strength)

DK-MY FIX ALU SUPPORT WITH ALUMINUM PLATES

Strength calculation values

Reference system of applied forces

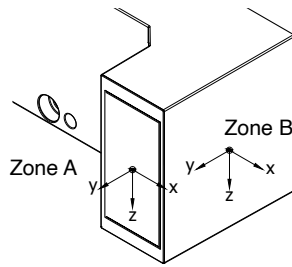

Zone A

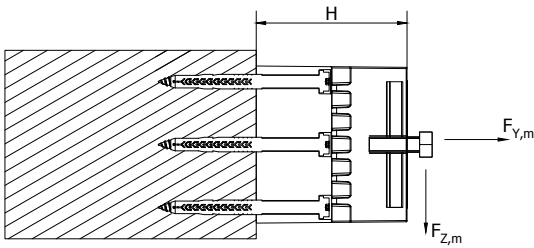

Zone B

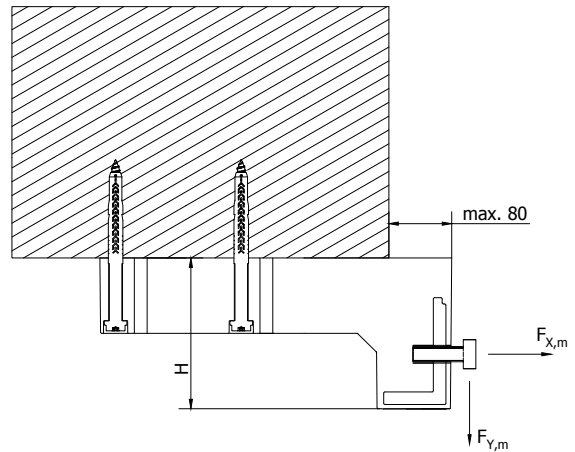
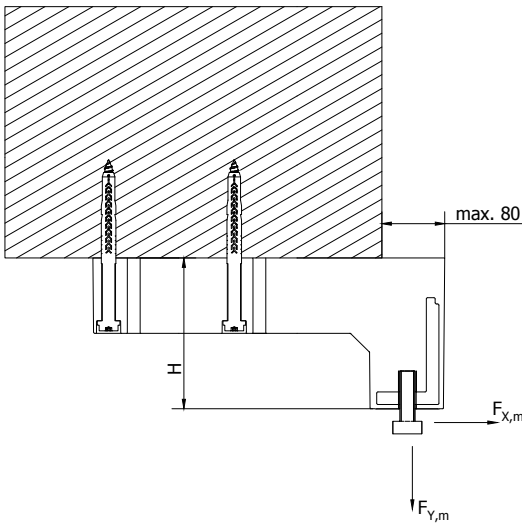
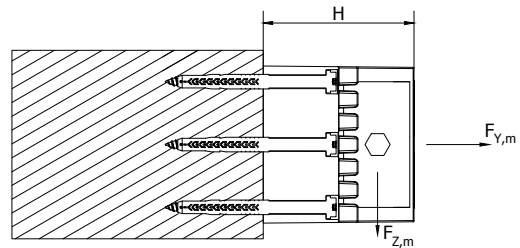

STRENGTH CALCULATION VALUES - γ_m included [kN]

DK-MY FIX ALU

area	unit	values							area	unit	values						
A	H (mm)	80	100	120	140	160	180	200	B	H (mm)	80	100	120	140	160	180	200
	F _{y,m}	5,43	5,33	3,64	2,58	3,05	3,00	2,55		F _{y,m}	5,09	6,31	5,35	5,3	4,22	4,36	3,75
	F _{z,m}	2,44	2,54	2,63	2,98	2,41	2,95	2,99		F _{z,m}	2,17	2,30	2,28	2,44	1,96	2,44	2,45
	F _{x,m}	1,67	1,99	1,78	1,80	1,45	1,35	1,35		F _{x,m}	1,89	2,30	1,95	1,47	1,79	1,69	1,36

Meaning Designation Forces [kN]:

F _{x,m} [kN]	Calculation strength of the transverse force of the mounting element
F _{y,m} [kN]	Calculation strength of the lateral tensile force of the mounting element
F _{z,m} [kN]	Calculation strength of the axial tensile force of the mounting element

The material safety coefficient $\gamma_m=3$ was considered

DK-MY FIX ALU SUPPORT WITH ALUMINUM PLATES

Reccomended loads

Reference system of applied forces

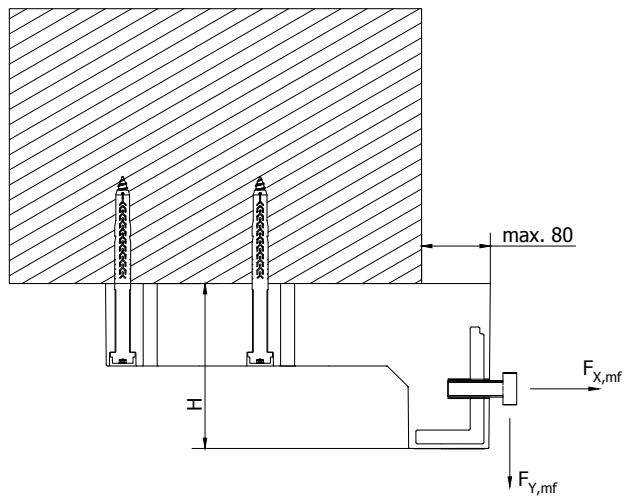
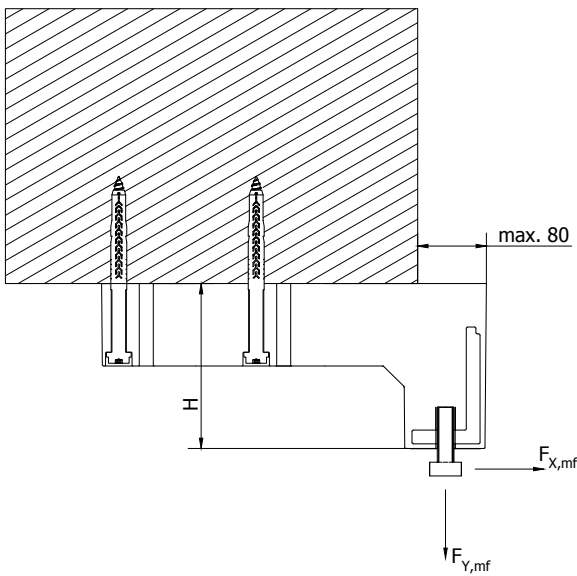
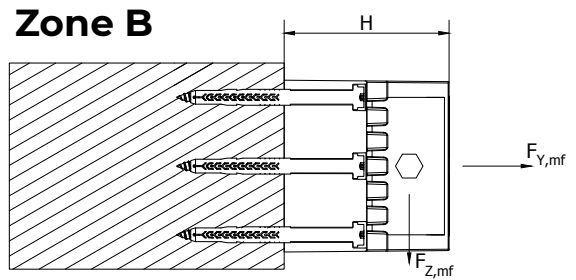
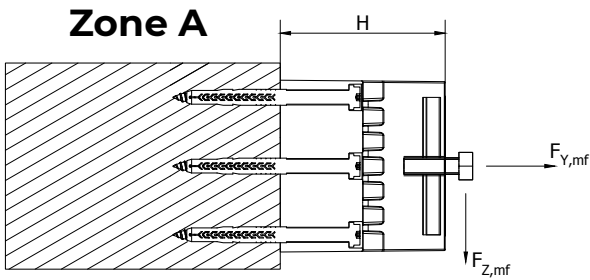
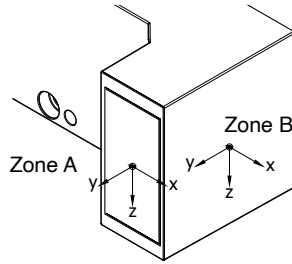

RECCOMENDED LOADS - γ_m and γ_f included [kN]																	
DK-MY FIX ALU																	
zone	unit	value							zone	unit	value						
A	H (mm)	80	100	120	140	160	180	200	B	H (mm)	80	100	120	140	160	180	200
	H1 (mm)	60	60	80	80	80	80	80		H1 (mm)	60	60	80	80	80	80	80
	F _{yf,mrec}	3,62	3,55	2,42	1,72	2,03	2,00	1,70		F _{yf,mrec}	3,39	4,20	3,56	3,53	2,81	2,90	2,50
	F _{zf,mrec}	1,63	1,69	1,75	1,99	1,61	1,97	1,99		F _{zf,mrec}	1,45	1,54	1,52	1,63	1,31	1,63	1,63
	F _{xf,mrec}	1,11	1,33	1,19	1,20	0,97	0,90	0,90		F _{xf,mrec}	1,26	1,53	1,30	0,98	1,19	1,12	0,91

Significato designazione Forze [kN]:

F _{X,mf} [kN]	Recommended transverse force of the mounting element
F _{Y,mf} [kN]	Recommended lateral tensile force of the mounting element
F _{Z,mf} [kN]	Recommended axial tensile force of the mounting element

DK-MY FIX ALU SUPPORT WITH ALUMINUM PLATES

8. INSTALLATION



01 Apply the insulation on the wall, leaving the space at the level of the first support.



02 Preparation of the DK-MY FIX substrate by applying specific adhesive.



03 Place the DK-MY FIX supports at the hinge fixing points.



04 Complete the laying of the insulation.



05 Wait 24 hours to allow the adhesive to fully adhere.

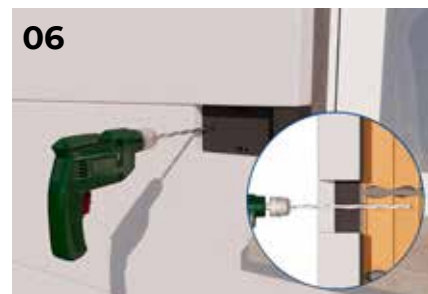

06 Drill at the relevant invitations.

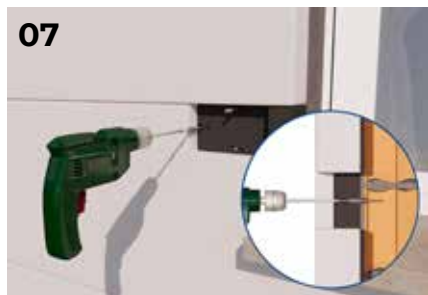

07 Mechanically anchor the DK-MY FIX bracket with the screw anchors provided.



08 Cover the substrates with the insulation material and finalize by applying the skim coat.



09 Finish the intervention with plastering

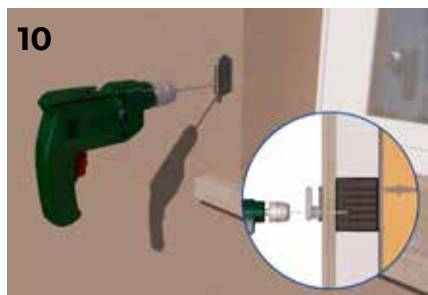

10 Attach the hinges to the DK-MY FIX support.



11 Mounting the shutters



WATCH THE VIDEO

DK-MY FIX ALU SUPPORT WITH ALUMINUM PLATES

8. INSTALLATION TIPS

Mechanical fixing requirements

It is necessary to check the suitability of the supplied fasteners for the present substrate as well as the scope of application. In case of unknown subfloor, it is necessary to make attempts to extract the fasteners before the beginning of installation on the object.

In case of load-bearing elements, the insertion of fastening pins into the masonry is not recommended.

In the case of load-bearing elements, the insertion of fastening pins into the masonry is not recommended. The elements should be fixed with threaded bars for epoxy resin or M8/M10 injection vinylester resin.

Mounting

Before installation, ensure that the hinge support elements have no visible damage and have not been exposed to the weather for a long time. The maximum projection varies according to the required distance between the edge and the fixing pin.

The hinge support components can be coated with existing commercially available materials for thermal insulation coating systems, without base coating.

The components can be set on plaster coating. In this case, the coating must support the compressive forces to which the screwing of the component is subjected.

For screw connections in hinge support elements, wood or self-tapping screws are suitable, as are those with cylindrical and coarse pitch threads (set screws) or screws with metric threads (M-screws).

Screw fastenings should be made only on the intended useful surfaces.

9. TECHNICAL SPECIFICATION

Item	Description	Unit	Price
Dak.B.ZIN35.1798/xxMY	Supply and installation of rigid, rot-proof, CFC-free Support, reinforced with two aluminum plates. Element supplied with 3 screw anchors for mounting. Sizes available from 80, 100, 120, 140, 160, 180 and 200 always for 125 x 280 mm. Made of PP (polypropylene). Used for inserting heavy load elements, such as the shutter rebate.		
Dak.B.ZIN35.1798/8MY	80 x 125 x 280 mm.....	pc.	-
Dak.B.ZIN35.1798/10MY	100 x 125 x 280 mm.....	pc.	-
Dak.B.ZIN35.1798/12MY	120 x 125 x 280 mm.....	pc.	-
Dak.B.ZIN35.1798/14MY	140 x 125 x 280 mm.....	pc.	-
Dak.B.ZIN35.1798/16MY	160 x 125 x 280 mm.....	pc.	-
Dak.B.ZIN35.1798/18MY	180 x 125 x 280 mm.....	pc.	-
Dak.B.ZIN35.1798/20MY	200 x 125 x 280 mm.....	pc.	-